

ACCUMULATION OF PREHEATED WATER FOR DHW NEEDS

TECHNICAL DESCRIPTION

The DHW thermal storage tank is designed for the accumulation and storage of water preheated in an external heat exchanger for domestic hot water needs. The tank's design includes two flanged inspection hatches, each with a cover, intended for periodic service maintenance of the tank and for installing flanged heat exchangers, enabling connection to additional heating sources. To protect the internal coating, one or more magnesium anodes are provided.

MATERIAL

The tank is made of S235JR (DIN 1.0038) carbon structural steel with an internal polycaramic coating that offers high adhesion to metal and elasticity, preventing microcracking due to thermal deformation of the tank walls. The external coating provides enhanced resistance to mechanical impacts and aggressive environments.

WARRANTY

5 years

THERMAL INSULATION

PL/PVC - 100 mm polyester insulation with a PVC cover and zipper closure.

PU/PVC - 90 mm flexible polyurethane foam insulation with a PVC cover, secured with straps.

PL/ABS - 100 mm polyester insulation with an ABS plastic cover and plastic locks.

PS/ABS - 100 mm high-efficiency rigid graphite-expanded polystyrene insulation with an ABS plastic cover. Premium-class insulation - fully complies with **ErP 2009/125/EC Directive**.

Tank	
P	T
6 bar	95 °C



Model	Tank volume, l	Energy efficiency class of insulation*
400	413	B
500	483	B
750	773	C
1000	1008	C
1500	1449	C
2000	2158	C
2500	2554	-
3000	3050	-
4000	4051	-
5000	5055	-
6300	6241	-
8000	8366	-
10000	10492	-

*Клас енергоефективності вказаний для ізоляції PS/ABS.

CUSTOM DRAW

Water heaters can be designed and manufactured according to customer requirements, allowing for modifications in dimensions and connection configurations.

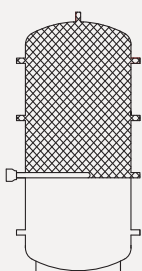
ACCESSORIES

Electric heat elements

Model	Heating zone volume, liters	2 kW	3 kW	4,5 kW	6 kW	7,5 kW	9 kW	12 kW	15 kW
		3-400							
		Heating time for ΔT=20°, minutes							
400	121	148	98	66	49	39	33	-	-
500	149	182	121	81	61	48	40	-	-
750	242	295	197	131	98	79	66	49	-
1000	318	388	258	172	129	103	86	65	52
1500	467	569	380	253	190	152	127	95	76
2000	708	863	575	384	288	230	192	144	115
3000	1020	1244	829	553	415	332	276	207	166
4000	1366	1665	1110	740	555	444	370	278	222
5000	1969	2401	1600	1067	800	640	533	400	320

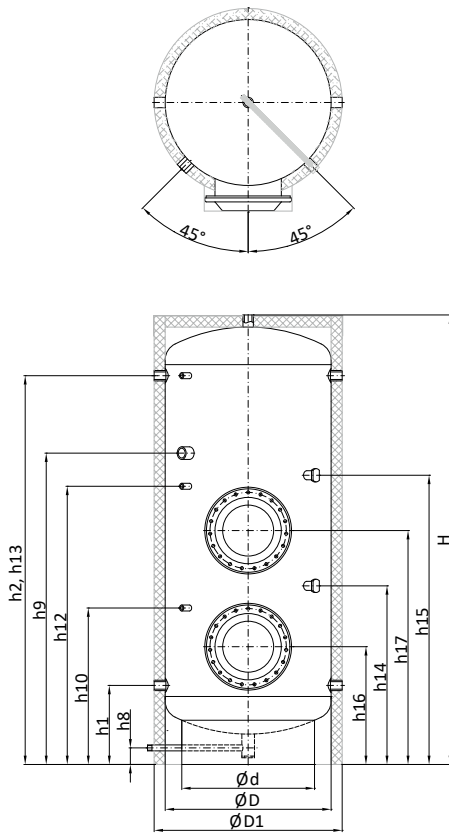

For alternative mounting of the electric heat element, a flange adapter is used

DIMENSIONS AND CONNECTION



DESIGNATION







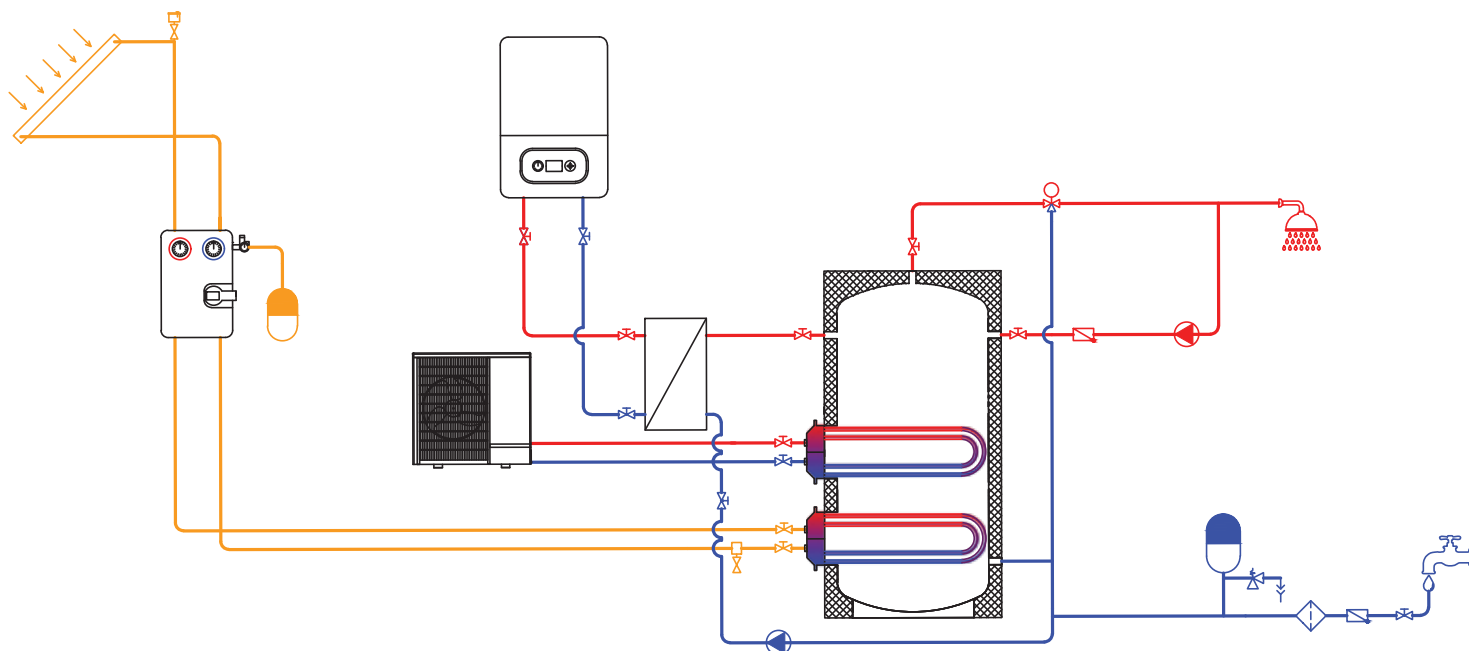











H	Hot water supply
h1	Cold water supply
h2	Recirculation. Alternative hot water supply or connection to another water heater
h8	Drainage
h9	Connection for electric heat element
h10, h12, h13	Connections for control, regulation, and measuring equipment
h14, h15	Connections for magnesium anode
h16, h17	Flanges for heat exchangers

Model	Dimensions, mm				Connection sizes, mm											
	ØD1	ØD	Ød	H	h1	h2	h8	h9	h10	h12	h13	h14	h15	h16	h17	
400	800	600	450	1730	331	1481	75	1231	681	1081	1481	781	-	456	906	
				1 1/4"		3/4"	1 1/2"	1/2"		1"	Ø210					
500	800	600	450	1980	331	1731	75	1381	681	1231	1731	781	-	456	1031	
				1 1/4"		3/4"	1 1/2"	1/2"		1"	Ø210					
750	950	750	600	2035	357	1757	75	1407	707	1257	1757	807	-	532	1057	
				1 1/4"		3/4"	1 1/2"	1/2"		1"	Ø300					
1000	1050	850	700	2085	390	1790	75	1440	740	1290	1790	840	-	565	1090	
				1 1/2"		3/4"	1 1/2"	1/2"		1"	Ø300					
1500	1200	1000	850	2170	430	1830	75	1480	780	1330	1830	880	1380	605	1130	
				1 1/2"		3/4"	1 1/2"	1/2"		1"	Ø300					
2000	1400	1200	1000	2260	471	1871	75	1521	821	1371	1871	921	1421	671	1171	
				2"		1"	1 1/2"	1/2"		1"	Ø350					
3000	1600	1400	1150	2365	526	1926	75	1576	876	1426	1926	976	1476	726	1226	
				2"		1"	1 1/2"	1/2"		1"	Ø350					
4000	1800	1600	1300	2425	557	1957	75	1607	907	1457	1957	1007	1507	757	1257	
				2"		1"	1 1/2"	1/2"		1"	Ø350					
5000	1800	1600	1300	2925	557	2457	75	1807	907	1770	2457	1007	1957	757	1507	
				2"		1"	1 1/2"	1/2"		1"	Ø350					
6300	2100	1900		Configuration and dimensions of connections available upon customer request.												
8000	2100	1900														
10000	2100	1900														

The schematic diagram does not replace qualified installation: during design, relevant standards and regulations must be followed.



DESIGNATION

- | | | | | | |
|---|---------------------------------|---|-------------------------|---|-------------------------------|
|  | Accumulation tank VTP 2 |  | Hot water supply |  | Three-way mixing valve |
|  | Gas/Electric boiler |  | Expansion tank |  | Shut-off valves |
|  | Heat pump |  | Solar circuit deaerator |  | Safety valve |
|  | Solar collector |  | Solar circuit air vent |  | Check valve |
|  | Solar circuit pump group |  | Circulation pump |  | External plate heat exchanger |
|  | Flanged U-shaped heat exchanger |  | Mesh filter |  | Drainage |
|  | Water supply | | | | |